

# AP-TOF

## 18mm Ultra-Fast Time-of-Flight Detector

### Applications

- ✓ Highest performance, fastest timing detectors for TOF mass spectrometry

### Features

- ✓ Improved mass resolution
- ✓ 350 picosecond pulse widths
- ✓ 250 picosecond rise time
- ✓ 18mm Ø collection
- ✓ Low profile 50Ω conical anode
- ✓ Replaceable MCP cartridge



The PHOTONIS **Ultra-Fast Time-of-Flight Detector** offers previously unobtainable levels of mass resolution, dynamic range, and detection sensitivity for Time-of-Flight Mass Spectrometry.

Our exclusive MCPs, with 2 microns diameter pores, offer the highest channel densities available. This channel density provides dynamic range improvements of ten times that of conventional microchannel plates.

In MALDI-TOF, ESI-TOF, or custom TOF Mass Spec, the mass resolution of your instrument is often determined by the detector. With our exclusive ultra-small pore microchannel plate technology and a new low profile, 50Ω impedance matched conical anode, PHOTONIS Ultra-Fast Time-of-Flight Detector provides ~350 ps pulse widths (~250ps rise time) - nearly ten times faster than conventional detectors.

These MCPs also give the Ultra-Fast Time-of-Flight detector superior sensitivity and excellent temporal resolution. The flat input surface provides uniform ion conversion and the higher aspect ratio of the MCPs provides gains in excess of  $5 \times 10^6$ . Installation is a snap with PHOTONIS replaceable Quick-Fit® MCP cartridge. Each cartridge includes a Chevron™ set of two Long-Life™ 2 micron pore Extended Dynamic Range MCPs, and a high transmission grid mounted in a rugged module. This module can be purchased separately and allows the operator to replace MCPs quickly and easily.

General Specifications		Unit
Microchannel Plate	Long-Life™ Extended Dynamic Range™	
Gain (minimum at 2400V)	$5 \times 10^6$	
Dark Count (maximum at 2400 V)	5	cps/cm <sup>2</sup>
Resistance (reference)	66 - 400	MΩ
Detection Diameter	18	mm
Operating Temperature Range	-50 to 100	°C
Operating Pressure (maximum)	$1.0 \times 10^{-6}$	Torr
Vacuum Flange	4.5" and 6" conflat available	
Electrical Connections	High Voltage: Output Signal:	SHV available with flange BNC available with flange
DC Offset Voltage on Output Signal (maximum)	500	V

### Detector Configuration (dimensions in inches except when specified)

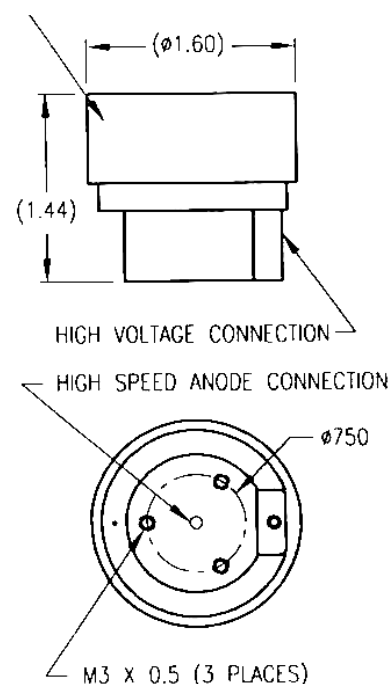

### Typical Pulse Width

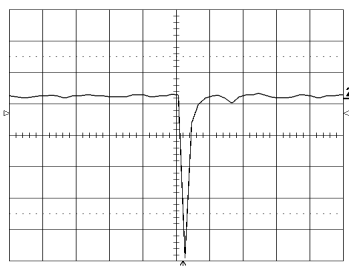

1 ns/div ; Rise Time ~250 ps ; FWHM ~350 ps

The information furnished is believed to be accurate and reliable, but is not guaranteed and is subject to change without notice. No liability is assumed by PHOTONIS for its use. Performance data represents typical characteristics as individual product performance may vary. Customers should verify that they have the most current PHOTONIS product information before placing orders. No claims or warranties are made as to the application of PHOTONIS products. Pictures may not be considered as contractually binding. This document may not be reproduced, in whole or in part, without the prior written consent of PHOTONIS.